



### TRANSDUCER MOUNTING PROCEDURE

Humminbird's high-speed transducer is supplied with your LCR. This transducer has been designed to give good high speed readings on most all boat designs, including aluminum.

Please carefully consider the following before installing your transducer.

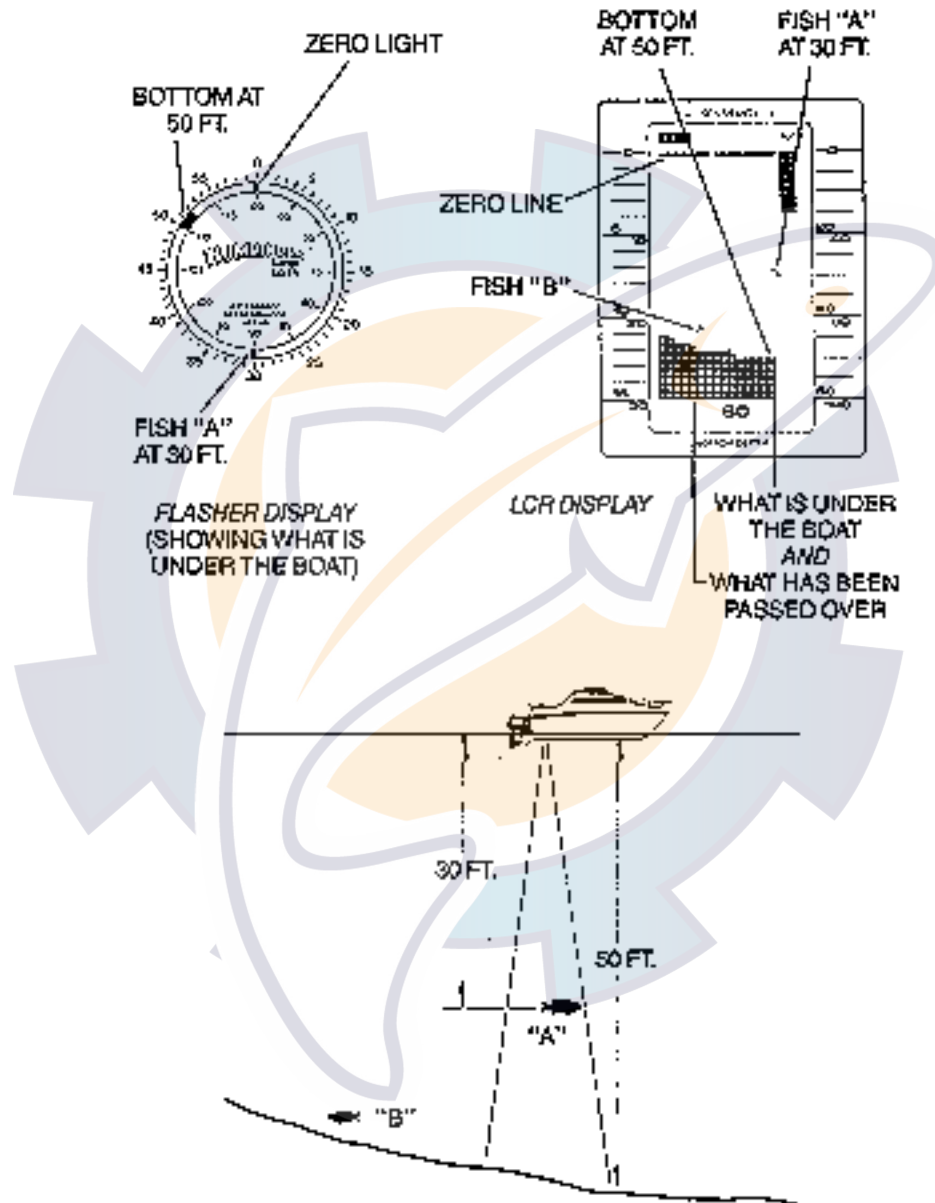

FIGURE 1

### TRANSDUCER MOUNTING OPTIONS

- A. Transom Mount- The Humminbird high speed transducer allows the transducer element to be mounted below the bottom of the boat hull keeping the transducer out of turbulent water and insuring good high speed operation. The transducer will absorb the blow of any obstruction

by rotating up out of the metal spring bracket without harming the transducer, or your boat. The transducer can be re-engaged by simply rotating the transducer down and snapping it back in place. (See Figure A)

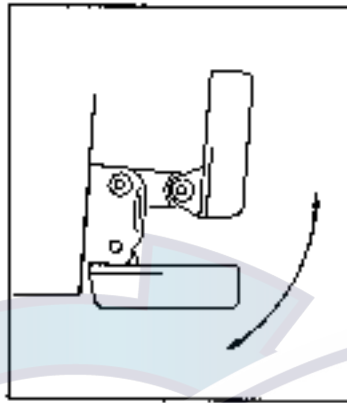

Figure A

- B. Inside Hull Mount- The high speed transducer can be mounted inside the hull (without pivot assembly) using the proper two-part epoxy, such as Humminbird's epoxy kit. Even though there is some loss of signal in shooting through the hull, your LCR will perform well with this type of installation. You cannot shoot through the hull of an aluminum boat.
- C. Trolling motor Mount- This type of transducer is not supplied with your LCR. It is designed to mount on the foot of a trolling motor. You may exchange your un-used high speed transducer for a trolling motor transducer. Call the Humminbird Customer Service Department.
- D. Bronz Thru-Hull Mount- This transducer is not supplied with your LCR but for an additional cost you may exchange your un-used high speed transducer for a bronz thru-hull. The bronz thru-hull transducer has a threaded stem which installs through a hole drilled in the boat hull, leaving the housing exposed under the boat. This type of installation must be used for many boats with in-board engines, because there is no suitable location on the transom away from the noise and turbulence created by the prop. A bronz thru-hull transducer should be installed by qualified personnel only.  
The LCR will operate well at high speeds with a properly mounted transducer. Remember, a transducer will not work transmitting through air or through air bubbles.

## 1. TRANSOM MOUNTING PROCEDURE

### Step 1.

**MOUNTING LOCATION-** It is important that the transducer be mounted on the transom where water flow is in constant contact with the transducer. You may wish to observe the rear of the boat while it is moving through the water to determine the best mounting location.

### Step 2.

**BRACKET INSTALLATION (Aluminum Boats)-** To install the metal bracket on an aluminum boat locate the template on the transom between rows of rivets, or ribs that are on the bottom of the boat. Align the template so that the bottom corner of the template nearest the center of the transom is on the bottom edge of the transom.

Figure B

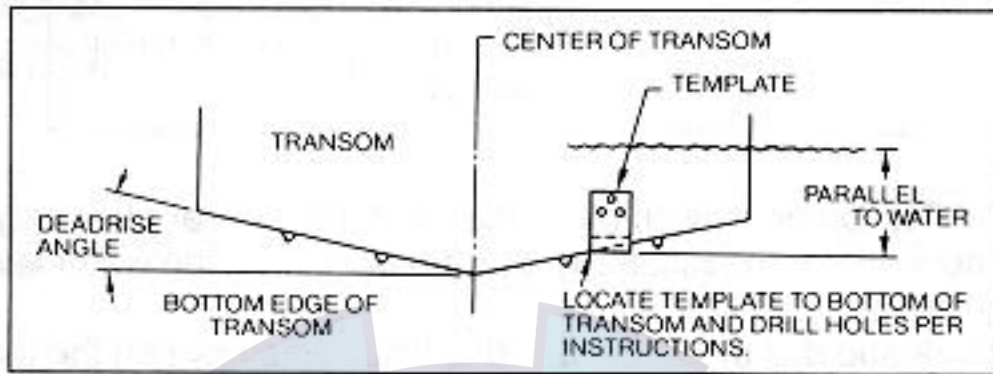

Once the location is determined mark and drill three 7/64" dia.. holes noted on the template. Attach the metal bracket using three #10 self threading screws supplied. Be sure to align holes in the center of the Bracket slots. On some aluminum boats it may be necessary to use a wood back-up plate. It is important to use a silicone sealant between the screwhead and bracket in order to prevent leaking. (See Figure C)

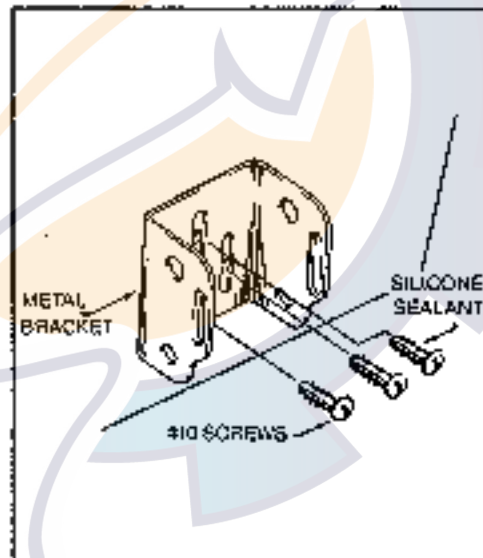
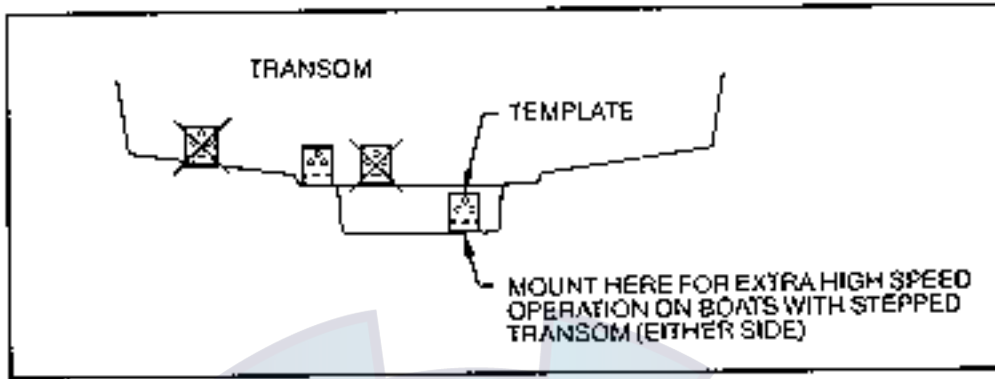

Figure C

Step 2.  
BRACKET INSTALLATION (Fiberglass Boats)- If your boat has a stepped transom located below and under the main transom, the compact transducer design allows mounting in this area. This mounting location is recommended for good reading at very high speeds. (See Figure D)

To install the metal bracket on a fiberglass boat, locate the template on the transom in the same manner as for an aluminum boat. (See Figure C)

Figure D



NOTE: On boats with more than 15 degree deadrise angle it may be necessary to mount the transducer slightly off parallel with the water level. (See Figure E)

Mark and drill the three 9/64" dia. holes as shown on the template. Attach the metal bracket using the three #10 self threading screws supplied. Be sure to align the holes so that they are centered vertically in the three slots found in the bracket. It is important to use a silicone sealant between the screwhead and bracket in order to prevent leaking.

Figure E

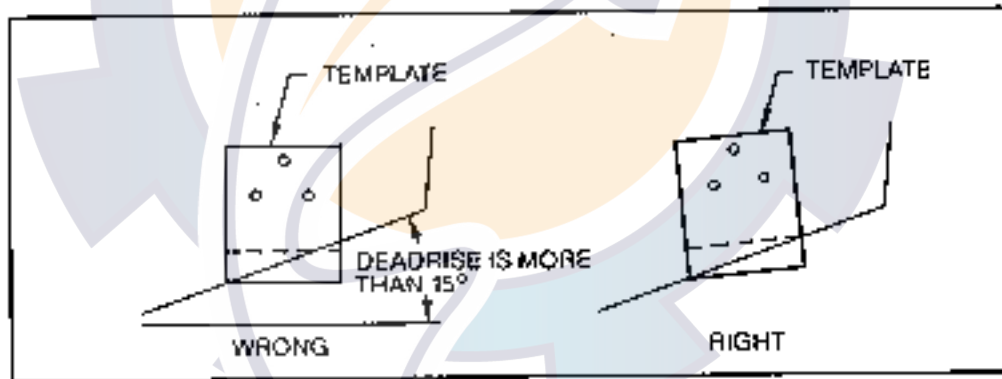

Step 3.

**TRANSDUCER PIVOT ASSEMBLY**- Assemble the pivot to the transducer main body using the two 1/4"x5/8" allen head screws, two 3/8" tooth washers and two, 1/4" square nuts. Make sure the tooth washers are sandwiched between the transducer main body and the pivot. The square nuts are trapped inside the pivot and will not rotate as the allen head screws are tightened. **HOWEVER, DO NOT TIGHTEN AT THIS POINT.** (See Figure F)

**CAUTION: DO NOT APPLY LOCTITE® OR SIMILAR LOCKING COMPOUNDS BECAUSE THEY WILL ATTACK THE PLASTIC.**

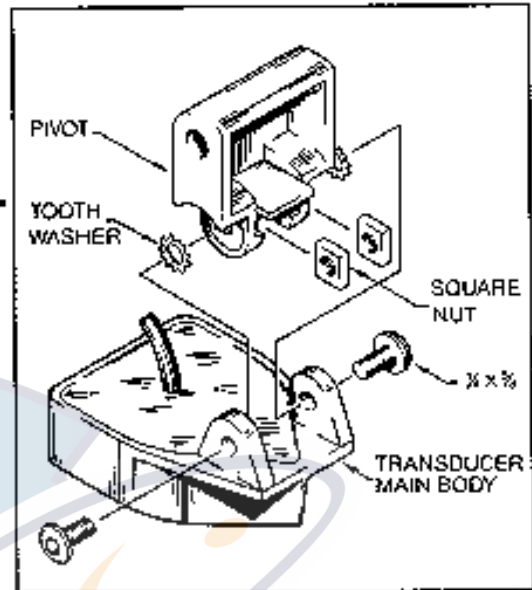

Figure F

Step 4  
TRANSDUCER ASSEMBLY- Insert the transducer assembly into the metal bracket from the bottom. Push up until the holes in the plastic pivot align with the uppermost holes in the bracket. Slide the O-ring on to the headed pin and insert it through the two parts. Assemble by screwing the 1/4"x3/8" allen head screw into the end of the pin and tighten. (See Figure G)

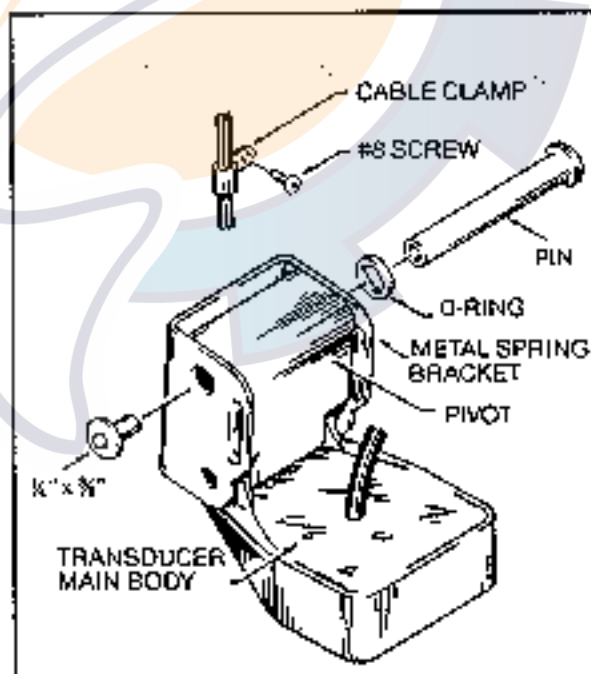
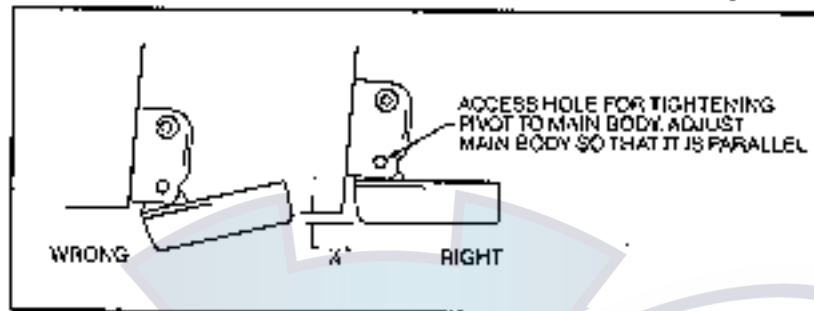

Figure G

Step 5  
ANGLE ALLIGHMENT- Set the transducer angle so that it is parallel with the bottom of the boat hull. Once proper alignment is achieved, tighten the two allen head screws using the 5/32" allen

wrench provided. The screws are visible through the access holes on each side of the metal bracket. Check to make sure the transducer main body is rigidly fastened to the pivot. (See Figure H)

Figure H



#### Step 6

**CHECK POSITION OF TRANSDUCER-** At this point, check to see that the bottom of the transducer is a minimum of  $\frac{1}{4}$ " below the bottom of the transom. (However, as noted in STEP 2, the top of the transducer cannot fall below the bottom of the transom). If it is not, remove the transducer assembly from the metal bracket by removing the pin installed during STEP 3. Loosen the metal bracket mounting screws, re-position the bracket utilizing its slotted holes, tighten and re-assemble. It may be necessary to replace the silicone sealant after this adjustment is made.

**NOTE:** It may be necessary to make several high speed runs to adjust transducer either UP/DOWN or to re-adjust the angle to achieve optimum results.

#### Step 7

**CABLE CLAMPS-** Install cable clamps as necessary by drilling a  $\frac{1}{8}$ " dia. hole for the # 8 screw supplied.

## 2. INSIDE HULL MOUNTING PROCEDURE

**Warning:** In order to achieve proper results with this type installation, it is important that the transducer be mounted by someone familiar with the use of two part epoxy adhesives. For this reason, Techsonic Industries, Inc. will not be responsible for any damage due to the mounting of your transducer in this manner.

**NOTE:** An Epoxy Kit (Part N. EPK) is available from Humminbird. This Epoxy Kit has been formulated for Inside Hull Transducer Installation.

1. Select as flat an area as possible near the aft end and center of boat where the hull is thin and not double. If the bottom has a runner down the center of boat, select an area to one side of the runner, but as close to the runner as possible.
2. Clean the inside of the boat with lacquer thinner in the area transducer is to be mounted. Outside of boat in this area should also be cleaned. (Not with lacquer thinner).
3. Put approximately one inch of water in the bottom of the boat.
4. Put transducer in the water. The bottom of the transducer should be in a flat area and should be in good contact with the bottom of the boat.
5. Operate the LCR with the boat operating at high speed. The transducer may have to be moved in order to find an area where satisfactory operation is observed.
6. When an area is found that produces satisfactory operation, mark the location of the transducer.

7. Remove the water and transducer and clean the marked area and the bottom of the transducer thoroughly.
8. Using the Humminbird Epoxy Kit or equivalent, mix an ample amount of epoxy without causing it to bubble and pour it in the area the transducer is to be mounted. The puddle should be larger than the bottom of the transducer.
9. Coat the bottom of the transducer with epoxy, then put it in the center of the puddle and push down on the transducer while moving it around in a circular motion. This forces out any air bubbles that may be trapped between the bottom of the transducer and the hull of the boat.
10. Let epoxy cure then the transducer is ready to operate. No water is now required in the bottom of the boat and gas and oil that is spilled inside of the boat will not degrade performance as it will if the transducer is placed only in water.  
CAUTION: Do not use the silicone seal or any soft adhesive to bond the transducer to the hull. This will reduce the sensitivity of the unit.

#### CAUTIONS

1. Occasionally the "eye" of your transducer may become dirty from storage or from contact with oils present in boats or marina environments. (Oil will cause the "eye" to lose the intimate contact with the water which is necessary for efficient operation.) The "eye" may be cleaned with liquid detergent.
2. Improper installation of the transducer can alter the efficiency and accuracy of the entire system.
3. If your boat or transducer is out of the water for a period of time, it may take a short period of time for the transducer to become thoroughly "wetted" when returned to the water. Also, re-entry may cause turbulence, which will create air bubbles in the "eye" of the transducer. The bubbles will disappear in a short time or can be removed by rubbing the transducer "eye" with your fingers while the transducer is in the water.
4. If your instrument should fail to function, be sure to check all the electrical connections before removing the transducer or calling a serviceman.
5. Inspect your transducer cable and make sure that it has not been cut or damaged to the point where it will affect the performance of the transducer. A slight nick or cut, exposing the outer cable, can be repaired by wrapping with electrical tape. A transducer can be damaged if the inner cable and outer cable are allowed to make contact. Such a problem can sometimes be corrected by properly splicing the coaxial cable. This should only be attempted by a qualified service technician.
6. If your LCR is not working properly and you suspect the problem might be in your transducer, we would recommend you borrow a unit from a friend and try it on your boat. If the symptoms are the same, you can almost be certain that the problem is in the transducer.

#### INSTALLING THE LCR

The LCR should be mounted on a flat, solid surface for maximum stability. The low profile swivel mount has four holes drilled in the base. It is recommended that all four holes be used.

Position the swivel base and drill four ¼" diameter holes. Note: The LCR hole pattern is the same as for all Humminbird flasher units. Use hardware provided to mount this base to the boat.

Next place the gimbal bracket on the swivel base and attach with four small machine screws, provided.

Place the LCR in the gimbal mount and make certain the rubber washers provided are placed between the unit and the gimbal bracket Important: Note which side of the gimbal faces forward. (Slots on gimbal bracket go towards rear). Also, rubber washer must be located between the unit and the gimbal bracket.



Install the mounting knobs and tighten snugly. The unit can now be swiveled and tilted to any desired position.

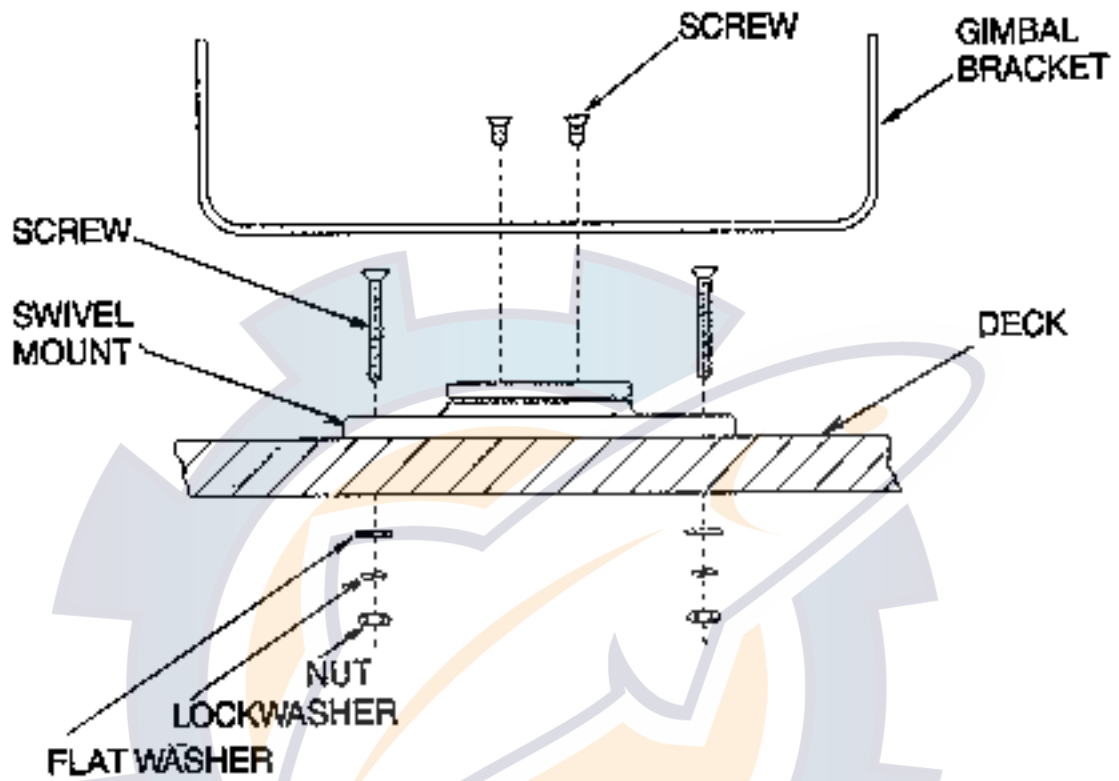

FIGURE 9

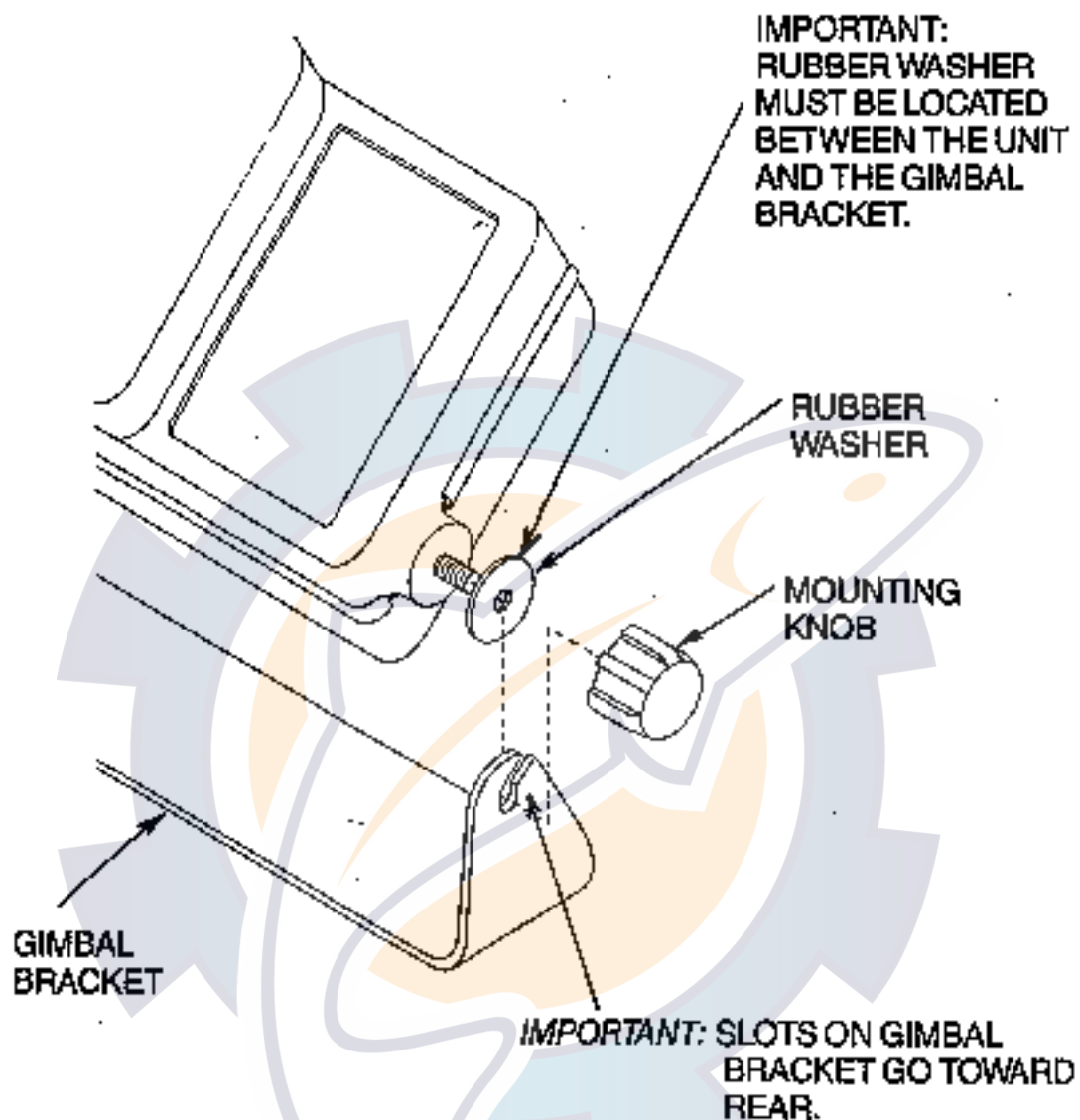

FIGURE 10

#### OTHER MOUNTING OPTIONS

1. The LCR gimbal bracket can also be mounted on the SM-4, quick disconnect swivel mount.
2. The LCR gimbal bracket can also be mounted directly to the dash without the swivel mount, however, this method is not recommended since the unit cannot be rotated.

#### INSTALLING THE CABLES

Your LCR comes equipped with Humminbird's new Angle-Lock power and transducer connectors. The power connector is identified with the letter P on the back of the plug.

It plugs into the outlet on the back of the unit marked "Power". The transducer connector is identified with the letter T and plugs into the outlet on the back of the unit marked "Transducer".

Note: An adapter (AD-4) is available to allow use of an old waterproof (BNC) transducer with the LCR, but be sure that the transducer is a 16-degree. A 32-degree transducer cannot be used.

A 1 1/8" hole must be drilled to pull through the transducer connector. After drilling the hole, pull the transducer connector up through the hole. If you are installing two units, both transducer connectors can be pulled through this 1 1/8" inch hole. Next, push the power cable wires down through the hole. A hole cover has been provided which will dress and hold the wires. Install the hole cover after determining the necessary wire length from the hole.

The power cable has a red lead to the positive (+) post and the black lead to the negative (-) post. Install a 1 amp fuse between the red cable and positive post of your 12-volt battery.

If a fuse panel is available, we recommend wiring the power cable into the fuse panel. Note: The LCR must be fused separately from any other accessory.

Your Angle-Lock connectors can only be plugged in one way. Position the connector so the letter P or T can be read and the 90 degree bend is pointed downward. Push the connector in as far as it will go. Turn the positive locking ring as far as it will go clockwise until you feel it lock. Locking ring as far as it will go clockwise until you feel it lock. Your connector is now locked into place.

Note: For easy access to the connectors, simply loosen the mounting knobs and tilt your LCR forward. The connectors are now in full view and easy to plug or unplug.

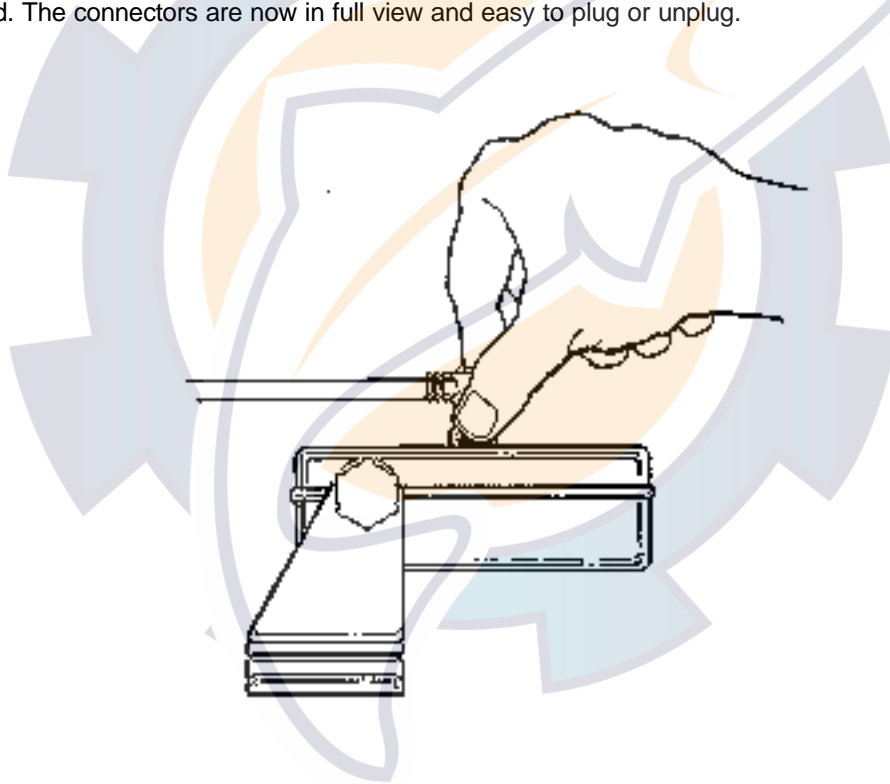

### MOUNTING THE DIMENSION 3

Before mounting the Dimension 3, gather the parts you need: Dimension 3, gimbal-mounting bracket, mounting hardware kit, power cable, transducer cable, and the cables for temperature and speed if used. If the transducer cable is not long enough for your installation, see "Accessories" earlier in this manual for information on the EC-7 10' extension cable.

Next, consider where to mount the Dimension 3. The gimbal mount offers mounting capabilities for the top of a shelf or the bulkhead (and lets you tilt the unit forward and backward for ease of viewing and operation). To choose the best location, consider the following:

- The mounting surface must be adequately supported to protect the Dimension 3 from excess wave shock and vibration.
- The mounting area should allow at least 2" clearance at the back, sides, and top of the unit for connection, air flow, and ease of removal.
- Any VHF radio you have may incur some degree of interference with the depth sounder. Humminbird depth sounders are designed to minimize this interference, but it is best to route the transducer cable and antenna cable as far away from each other as possible - for example, on opposite sides of the boat.

After you have determined the best location for your Dimension 3, proceed with the instructions on the following page.

1. Position the gimbal mount with the Dimension 3 unit on the mounting surface. The slots which hold the unit should face to the rear. 2. Remove the unit without moving the bracket and mark 1/8" holes for the mounting screws. 3. At least 3" behind the bracket, mark a 1" hole to run the cables through. 4. Set the gimbal mount aside and drill the holes as marked. 5. Mount the bracket, using the mounting hardware supplied with your Dimension 3. (Note: Twist the bracket 90 degrees on the swivel base to access the mounting screws.) 6. To connect the power cable to the 12-volt DC power source, wire the Dimension 3 through your fuse panel with a 1-amp fuse (not included).

If your boat does not have a fuse panel, you can wire the power cable to the battery with an in-line 1-amp fuse and fuse holder (not included) in the positive wire, as shown below. Do not connect directly to the battery without a fuse. Attach the black lead to the negative (-) terminal, and wire the red lead through the fuse to the positive (+) terminal.

**NOTE:** Do not use any power cable other than the one provided with your Dimension 3.

7. Pull the transducer and power and accessory cables up through the 1" hole behind the gimbal bracket, and connect them to the back of the Dimension 3.
8. To "dress" the 1" hole and hold the cables securely, push excess cable into the hole, and install the hole cover provided with your unit.
9. Loosen the mounting knobs and slip the Dimension 3 unit into the gimbal bracket. Be sure to keep the rubber washers between the bracket and the unit. Tighten the knobs to hold the Dimension 3 in viewing position.

After installing your transducer, Dimension 3, and cables, you should test the installation. Testing should be performed on the water, since that is the only way to check your transducer's performance.

With your boat at idle, press the POWER button to turn the unit on. The Dimension 3 performs a self-test on its electronics, then automatically selects the right depth range and sensitivity level for conditions. Momentarily, you'll see the reading start to "march" across the screen from right to left and a digital depth readout in the lower right corner.

Increase your boat speed to ensure that you get a continuous bottom reading as the boat moves. Your transducer is designed to operate at up to 75 mph, so feel free to test them at high speeds.

If the Dimension 3 performs well at idle or slow speeds, but the display is not continuous at higher speeds, the transducer is not installed properly. Air bubbles or turbulence from the boat hull are passing across the transducer face, blocking the transmitted signal. By following the instructions in "Mounting the Transducer," you can make simple adjustments that should fix the problem.

NOTE: If other problems occur, see "Troubleshooting" later in this manual for tips from the Humminbird engineers. If you don't find the solution there, call our toll-free Customer Service Hotline.

## BASIC OPERATIONS



This section explains how to run the Dimension 3 simulator for practice and how to start the Dimension 3 for actual use. You're also shown how to use the "screen control" buttons-the buttons that let you control the display of underwater images on the Dimension 3 screen.

You should read this section and Section S, "Selecting Dimension 3 Functions," as you first learn to use the Dimension 3. Doing so will ensure you make the most of its many features.

The first part of this section explains the built-in simulator. The remaining instructions can be followed while using the simulator or in actual operation.

## USING THE BUILT-IN SIMULATOR

The Dimension 3 includes a built-in simulator that helps you learn to use your new equipment. The simulator displays a typical underwater scene, and lets you practice with the controls.

The unit must be turned off before you start the simulator. To activate it, press down and hold the POWER button until a chirping sound begins. Release the button, and the built-in simulator begins displaying a typical Dimension 3 reading.

You can use the simulator to learn the functions explained in the rest of this manual, just as if you were getting actual on-the-water readings. To turn off the simulator, turn off the unit by pressing the POWER button again.

Of course, the best way to learn is with actual use, especially in familiar waters. If you know what's below and see it on-screen, you'll quickly become a Dimension 3 expert.

### POWERING UP FOR ACTUAL USE

The Dimension 3 offers function selection with front panel buttons. (Note that to select something with a button, you must press it fully so that you hear a chirp" sound.) This section explains the Power and Light buttons. Plus the "Screen Control" buttons arranged in a circle.

You can learn to use these features by actual operation, or when using the simulator.

Press the POWER button once to turn the Dimension 3 on. Pressing it again turns the Dimension 3 off. When the unit is off, keeping POWER pressed for about 2 seconds starts the built-in simulator.

The LIGHT button controls the 2-position backlight. Press LIGHT once to turn the backlight on dim, pressing a second time will turn the backlight to bright. Pressing a third time will turn the light off.

In either actual operation or simulation, you see a 3-Dimensional, underwater image that shows the bottom, any objects between the bottom and your boat, and such information as the current depth and temperature and your current speed.

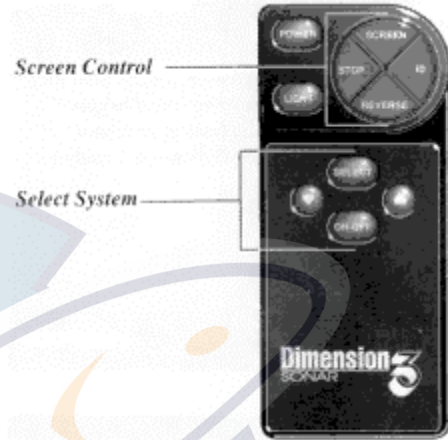

### WHAT YOU SEE ON-SCREEN

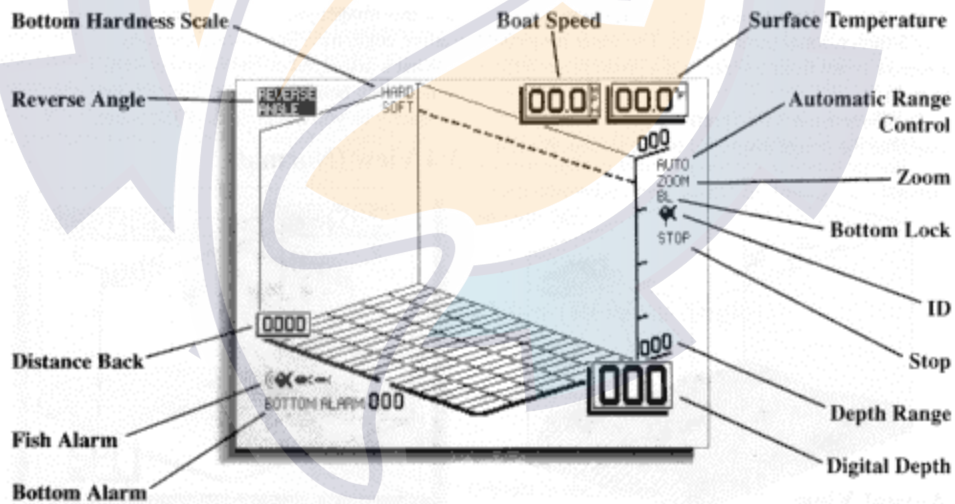

The 3-dimensional image you see reflects the way 3-dimensional sonar works. The sonar projects a narrow beam front-to-rear, and a broad beam left-to-right.

The Dimension 3 interprets the sonar returns to assemble the image displayed on the screen. As you view this image, your boat is at the center of the leading edge, traveling toward the right.

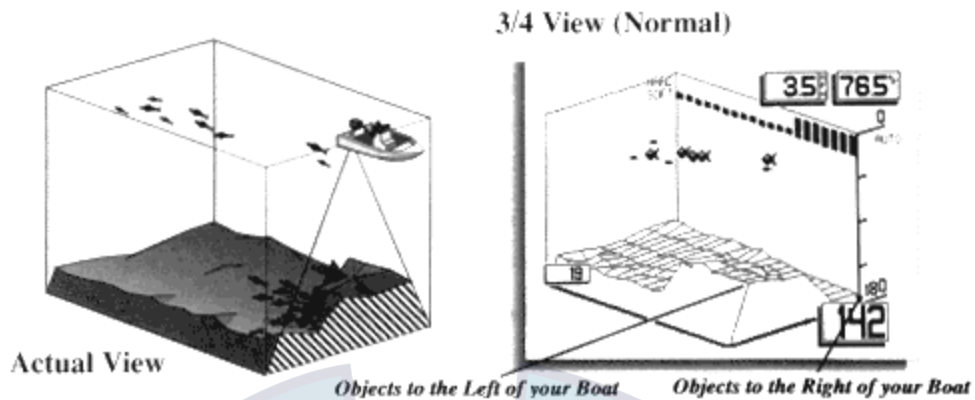

What's displayed on the screen is what's immediately behind you. The image is updated constantly as you travel through the water.

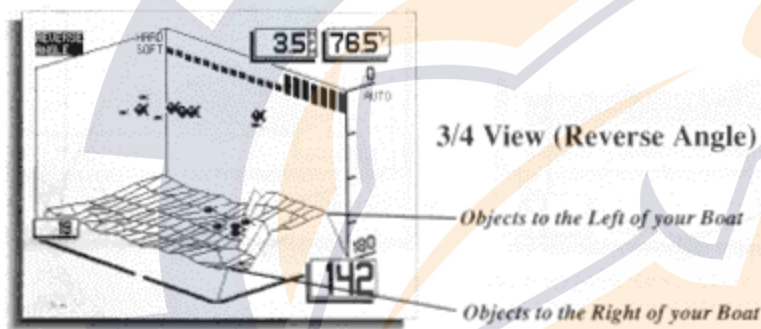

There are two options on how to display the three dimensional image on the screen; normal and reverse angle. Once you select the method you prefer, the Dimension 3 will remember that setting even if the unit is turned off. Reverse angle, as shown below, is as if you were forward and to the right of your boat looking back on the area you have covered. Normal view

is the reverse of this, so objects to the right of your boat appear on the right of your screen. By experimenting with these two options while in or around known terrain, you can decide which you prefer. By switching between normal 3/4 view and reverse angle, it is often possible to reveal terrain which otherwise might be hidden from view. (Shown on page 26).

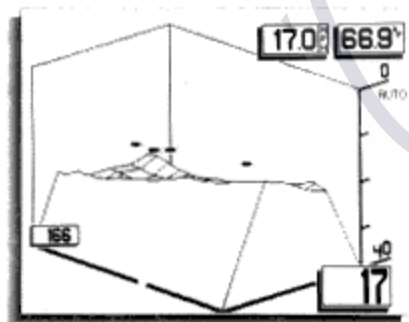

Screen with high bank blocking the view of bottom structure.

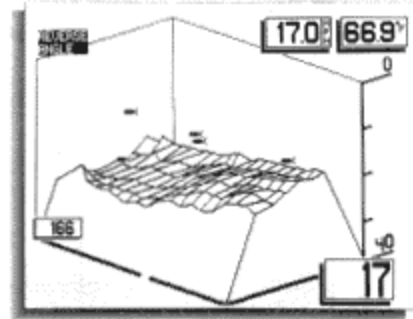

Screen with Reverse Angle activated shows the bottom that would normally be blocked.

Straight-On View

Side View

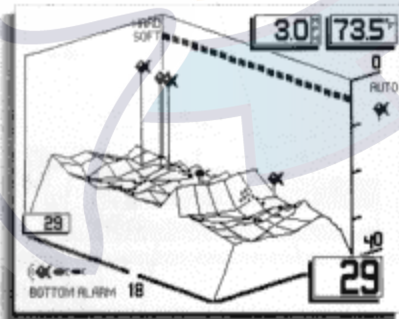
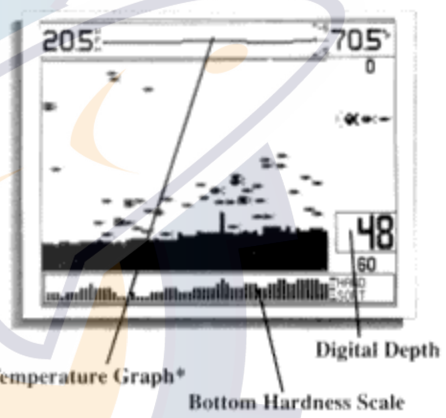
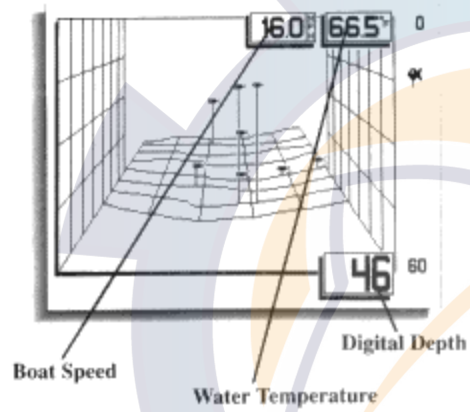





3 sizes of fish symbols are used to depict fish.



Structure or thermoclines are shown with this symbol.



ID "ties" the fish to the bottom beneath it for easy location.

### CONTROLLING THE SCREEN IMAGE

The buttons arranged in a circular pattern on the Dimension 3 front panel let you manipulate this image.

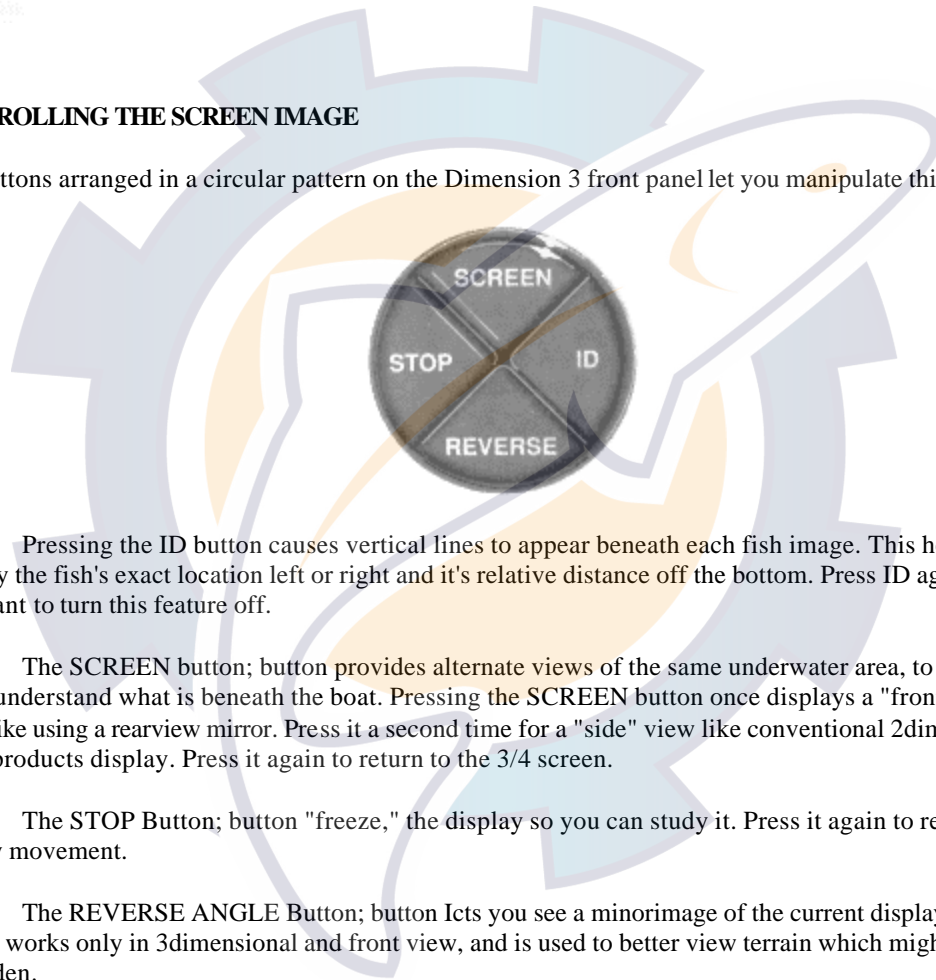

Pressing the ID button causes vertical lines to appear beneath each fish image. This helps you identify the fish's exact location left or right and it's relative distance off the bottom. Press ID again when you want to turn this feature off.

The SCREEN button; button provides alternate views of the same underwater area, to help you better understand what is beneath the boat. Pressing the SCREEN button once displays a "front" view, much like using a rearview mirror. Press it a second time for a "side" view like conventional 2dimensional sonar products display. Press it again to return to the 3/4 screen.

The STOP Button; button "freeze," the display so you can study it. Press it again to restart the display movement.

The REVERSE ANGLE Button; button lcts you see a minorimage of the current display. This feature works only in 3dimensional and front view, and is used to better view terrain which might normally be hidden.

### SELECTING FUNCTIONS

The previous section explains the buttons that let you control the display of screen images. This section shows you how to use the Dimension 3 "Select System" to choose from a wealth of useful features and functions.

When you press the SELECT button, you see a menu that offers the following functions for further adjustment:

- Sensitivity

- Depth Range
- Bottom Alarm
- Fish Alarm
- Zoom
- Bottom Lock
- Bottom Hardness
- Display Speed
- Data Log

To adjust any of these, press SELECT until a menu appears for the function you want. (The list rotates by one choice each time you press SELECT)

As you select a function, on-screen instructions tell you how to use the arrow buttons and ON-OFF for adjustment. When first learning, you should also refer to the following pages.

After you adjust any function, the display returns to its full- screen reading. Note that the last function you select stays "active"-you can adjust it without having to press SELECT again. For example, if you often use Zoom, you can select it once, then switch it on and off by simply pressing ON-OFF. The menu Select System works in all three views although the following descriptions are illustrated in the 3/4 view unless there are significant differences in operation.

## 1. Selecting Sensitivity; Factory setting: +3

The Dimension 3 automatically adjusts to the proper amount of sensitivity for conditions (i.e. depth). You can bias the setting + or - 5 levels to suit your personal taste. Increasing the sensitivity adjustment can cause the display of very small targets and thermoclines which might not be displayed at a lower level.

If you want to manually adjust Sensitivity, select SENSITIVITY and press the Up or Down arrow button to adjust the sliding display. For example, if you press the Up arrow twice to move the slide two blocks, Sensitivity remains 2 settings higher than the normal automatic setting

UP-DOWN buttons control display sensitivity

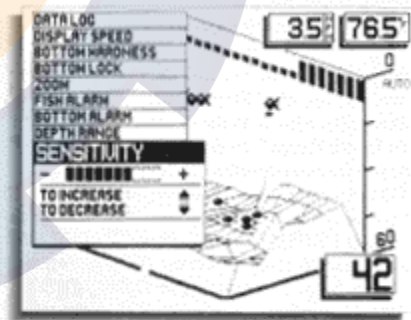

 UP-DOWN buttons control display sensitivity

## 2. Setting Depth Range:

Factory setting: ON (Automatic)

When you turn the Dimension 3 on, it finds the bottom, sets the ideal Depth Range, and automatically adjusts as the depth changes. In this "Auto Depth Range" mode, the bottom is always displayed for easy-to-understand readings (and AUTO appears at the right of the screen).

If you prefer, you can turn Auto Depth Range off. Select DEPTH RANGE, press ON-OFF, and adjust the Depth Range with the Up or Down arrow key. You can select depth ranges to 240' when in the 3/4 view, or front view, or to 600' in the side view. If you have selected the 360', 480', or 600' range in the side view and switch to the front view or 3/4 view, the maximum range for those views (240') will be displayed.

In this "Manual Depth Range" mode, the screen shows a flat grid if the bottom is below the depth you have set.

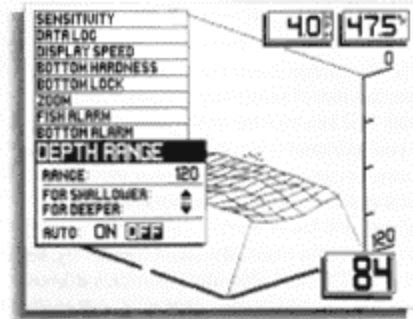

UP-DOWN buttons are used to adjust the depth range

ON-OFF button turns the automatic depth range on and off

## DEPTH LIMIT MESSAGE

As the bottom depth approaches the depth limit (240') a depth limit message appears in front and 3/4 views or when a menu item such as zoom or depth range is adjusted to the maximum allowed value.

The message stays on the screen for several seconds and reminds the user that switching to the side view will enable the unit to chart the bottom to 600'.

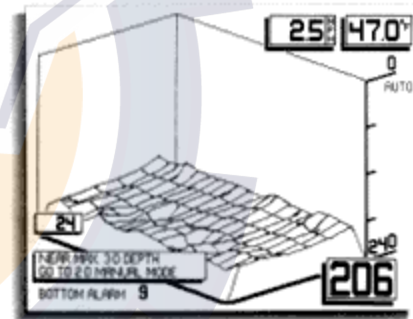

## 3. Enabling Bottom Alarm

Factory setting: OFF

The Bottom Alarm lets you specify the minimum depth you want to maintain. To use it, select BOTTOM ALARM, then, press the ON-OFF button to activate the alarm, and the Up or Down arrow key to adjust the depth at which the alarm will sound. The Bottom Alarm indicator and the selected depth are displayed when the function is on.

While Bottom Alarm is on, you'll hear a continuous chirping sound when the bottom directly under your boat gets shallower than you defined. This is very handy for alerting you to shallow water or helping you to maintain position over structure.

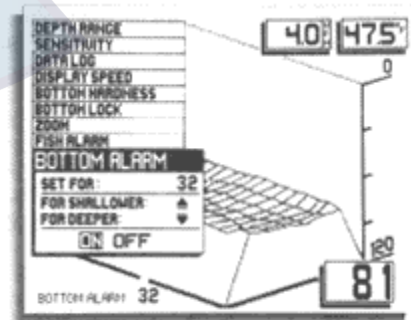

UP-DOWN buttons adjust the depth for the bottom alarm to sound

ON-OFF button is used to activate the bottom alarm



4. Enabling Fish Alarm;  
Factory setting: OFF

The Fish Alarm alerts you with a chirping sound whenever the Dimension 3 detects fish (or other objects above the bottom). You can set it for large fish, large and medium fish, or all fish.

To activate it, select FISH ALARM and press ON/OFF. The alarm is initially set for large fish; press the Up or Down arrow to display available settings. An on-screen fish symbol shows the current setting when the alarm is on.

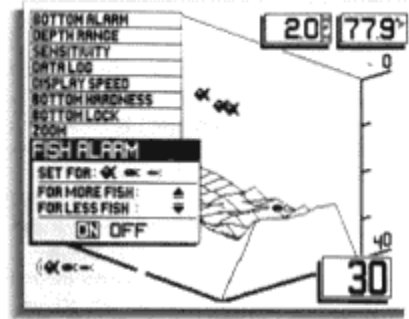
NOTE: Displayed fish sizes generally indicate relative fish size, but different species may have different sonar characteristics. Strength of return is connected for depth, so shallow fish don't appear longer than deeper fish.



-  UP-DOWN buttons are used to adjust the fish alarm for different size fish
-  ON-OFF button is used to activate the fish alarm



5. Using Zoom;  
Factory setting: OFF

Zoom provides an up-close view. To activate it, select ZOOM. Press the Up and Down arrows to move the Zoom range to the area you want, and press ON-OFF. The range of the display is shown when Zoom is on and is selected automatically based on the current depth range. The vertical lines on the three corners show the zoom area selected.

Zoom range depends on the current Depth Range. The deeper the depth, the broader the zoom range. Possible zoom ranges are 10', 20', 40', and 60'.

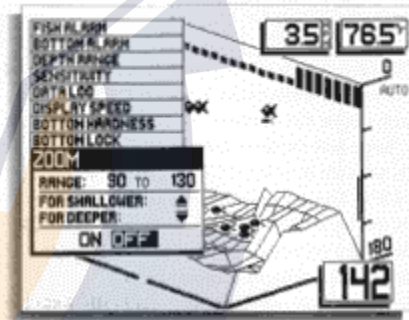
Remember: If Zoom is the last function selected, you can use the arrow buttons to adjust Zoom depth or ON-OFF to switch between Zoom and full view without pressing SELECT first.



-  UP-DOWN buttons control the zoom range
-  ON-OFF button switches between normal and zoom views

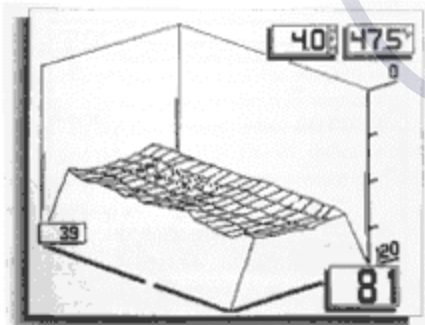

Vertical bars show area to be enlarged before zoom is activated...

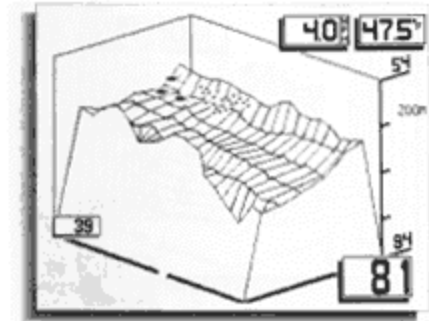

...and the same view after zoom is activated

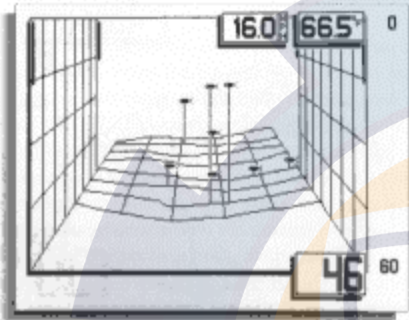

Vertical bars also indicate zoom area in the straight-on view

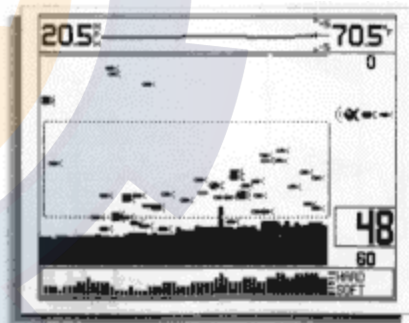

Horizontal lines indicate zoom area in the side view

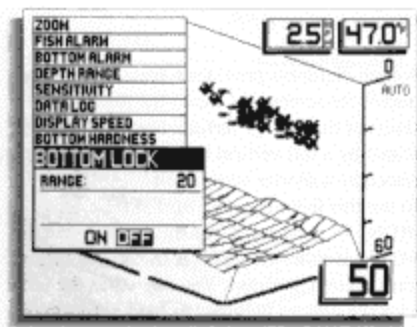

6. Using Bottom-Lock;  
Factory setting: OFF

Bottom-Lock provides an up-close view like Zoom, except that in this case the zoomed view automatically moves up or down to stay on the bottom. To use this feature, select BOTTOM LOCK and press ON-OFF. The BL indicator and the range of the display are shown when BottomLock is on.

This is an ideal feature for finding structure or locating fish near the bottom.

Remember: If Bottom-Lock is the last function selected, you can use the ON-OFF button to switch Bottom-Lock on and off without having to press SELECT first.

 ON-OFF activates the bottom lock function (Range is selected automatically by the depth range)

7. Using Bottom-Hardness:  
Factory setting: OFF



Bottom-Hardness provides a special display at the top of the screen that shows the relative hardness of the bottom surface. Hard surfaces are indicated by a full vertical bar, and soft surfaces are indicated by a shorter vertical bar.

To use this feature, select BOTTOM HARDNESS and press ON-OFF.

NOTE: Bottom-Hardness is factory set for average bottom hardness. You can adjust the scale so a known bottom will read as hard, medium or soft; this will aid in comparisons of other "unknown" terrain.

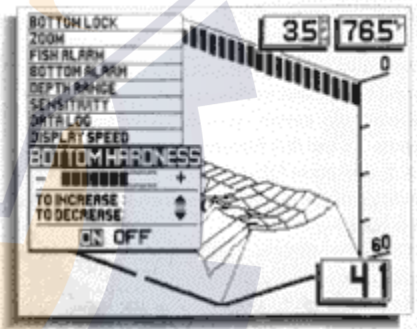
To adjust the bottom hardness scale, use the Up and Down arrows to move the sliding display. The bottom-hardness scale is not displayed in the straight-on view.



 UP-DOWN buttons are used to increase and decrease sensitivity of the bottom hardness scale  
 ON-OFF button is used to activate the bottom hardness function

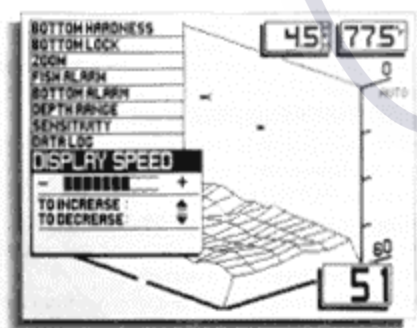

8. Setting Display Speed;  
Factory setting: Maximum

The Dimension 3 display is "updated" (advances across the screen) as you move through the water. The speed at which the display is updated depends on the Display Speed setting. To adjust it, select DISPLAY SPEED, and press the Up arrow for a faster setting or the Down arrow for a slower setting.

In general, higher Display Speed settings provide faster updates, while slower Display Speeds provide more detailed information.

 UP-DOWN buttons are used to increase and decrease the speed of the display

Display speed affects how much "history" is shown; slower display speeds will increase the distance of bottom on screen.

9. Displaying the Data Log;  
Factory setting: Off

The Dimension 3 Data Log provides a full screen of information on current conditions. To display it, select DATA LOG and press ON-OFF.

All log information is continuously updated as long as the Dimension 3 remains powered on. If you want to reset Average Speed, Elapsed Time, and Elapsed Distance, press the STOP button.

Pressing ON-OFF exits the Data Log and returns you to normal Dimension 3 operation.

NOTE: Data Log requires proper input from the temp and speed accessories on the transom of the boat.

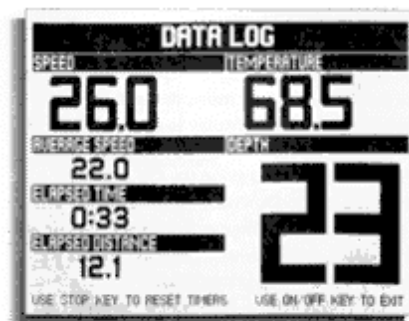

ON-OFF button is used to activate or deactivate the Data Log

### USING THE CUSTOM PROGRAM

The Dimension 3 lets you customize three aspects of its operation:

1. You can "hide" from the Select System any feature you never select. This means that, when you press the SELECT button, only those functions you use appear for further adjustment. 2. You can choose whether distances are measured in feet, meters, or fathoms; whether speed is shown as miles per hour, kilometers per hour, or knots; and whether temperatures are displayed in fahrenheit or centigrade. 3. You can adjust screen contrast to optimize viewability for your mounting location.

To do any of these, press the SCREEN button and hold it for 3 seconds. Release it when the Custom Program menu appears.

The SELECT button selects a function for adjustment The UP-DOWN buttons are used to select specific features or adjust contrast ON-OFF hides the selected function



The SELECT button selects a function for adjustment  
The UP-DOWN buttons are used to select specific features or adjust contrast  
ON-OFF hides the selected function

As noted on the top of the Custom Program screen, you can press the SELECT button to choose a category. Proceed as follows:

You can "hide" seldomused features to reduce the features or menus accessed by the Select button. This allows you quicker access to those features you use frequently. To hide a feature, press the SELECT button until the box before FEATURE HIDE is blacked in. Then, press the Up or Down arrow to select the feature you want to hide, and press ON-OFF. When you move to another selection with the Up or Down arrow, notice that "H" now appears before the feature to remind you it is hidden. (You can repeat the process of selecting an item if you decide later that you want to restore it.)

To select a unit of measurement, press the SELECT button until the box before UNITS is blacked in. Then, press the Up or Down arrow to select the unit to change. Press ON-OFF until the unit you want is displayed.

To adjust the contrast of the Dimension 3 display, press the SELECT button until the box before CONTRAST is blacked in. Then, press the Up or Down arrow until the screen shows the desired degree of contrast.

When you are finished with the Custom Program screen, press the SCREEN key to return to normal Dimension 3 operation.

